

Key Facts:

Connectors:	JST-GH, M4 Screw Terminals, Solderpads (version dependend)
Dimensions [mm]:	45 × 100 × 15
Mounting Holes:	4 × 3.2mm
Weight [g]:	45.0
Firmware:	VESC®
Supported Sensors:	Hall, ABI, SinCos, SPI
Logic output voltage [V]:	5.0
Logic supply current [A]:	0.5
Minimum input voltage [V]:	13.0
Maximum input voltage [V]:	84.0
Maximum battery current [A]:	140.0
Maximum motor current peak [A]:	200.0
Maximum duty cycle [%]:	97.0
Current sensor type:	Phase Shunts

*maximum currents are highly dependent on the cooling solution

And most importantly:
Have fun and enjoy the product!

Warnings:

- The device must be operated within its specified limits; exceeding ratings even temporarily may result in failure or hazardous conditions.
- Do not modify the device or enclosure under any circumstance.
- Opening the device voids all warranty and may interfere with its functionality.
- This product is not certified for use in safety-critical or human-carrying systems unless explicitly stated by the manufacturer.
- The user is solely responsible for ensuring compliance with all applicable laws, regulations, and certification requirements.
- The manufacturer and seller are not liable for any damage, injury, or loss resulting from improper use, installation, or operation.
- In no event shall the manufacturer or seller be liable for indirect, incidental, or consequential damages.
- The manufacturer assumes no responsibility for system-level failures, including but not limited to loss of propulsion, control, or power.
- Redundant safety systems are strongly recommended for any flight application.

Pinout:

1: Combined Header

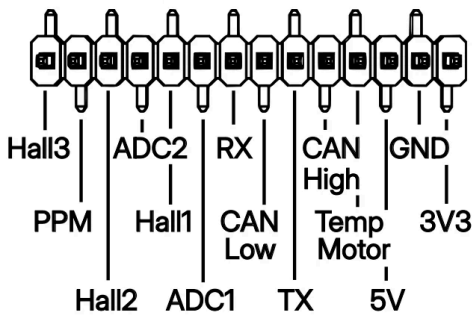

Breakout-Board:

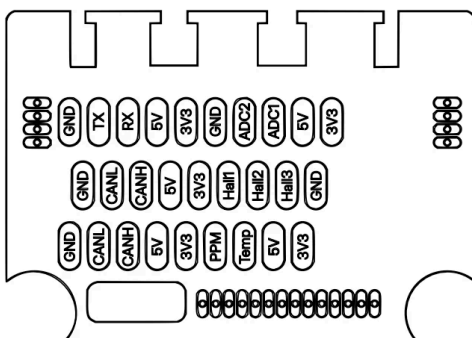

Installation:

- Always install an appropriately sized DC supply fuse near the controller.
- Installation must be carried out by qualified personnel experienced with high-voltage systems and VESC-based motor controllers.
- Read and understand all instructions and safety notes before starting.
- Prepare all required tools and materials, including wiring, connectors, insulation, and protective equipment before installing.
- Ensure the battery and motor system are properly arranged, with correct wiring paths and secure mounting.
- Make sure to not exceed the maximum torque of 1.5Nm on all screw terminals.
- Mount the device securely (using threadlock) in a location protected from vibration, moisture, dust, and heat.
- Do not install in areas exposed to water, condensation, or flammable materials.
- Install motor temperature sensors as required to enable thermal protection and controlled current reduction.
- Check polarity on all connections; incorrect wiring can cause permanent damage. Verify against the wiring diagram.
- Insulate all exposed terminals and wires to prevent short circuits or electric shock.
- Keep all metal objects and tools away from power terminals during installation.
- Secure and route cables properly to prevent movement and wear.
- Recheck all wiring and connections before applying power.
- Never connect the controller directly to a voltage source (like a battery) without a precharging mechanism.